

PRESSURE GAUGE



TECHNICAL DATA

MODELS	HDP-1, HDP-2
DIAL SIZE	HDP-1 - 90mm (3.5") HDP-2 - 100 mm (4")
CONNECTION	1/4" BSPT (standard supply) 1/4" NPT (optional)
RANGE	HDP-1 - 0 to 21 kg/sq.cm & 0-300 psi HDP-2 - 0 to 21 kg/sq.cm & 0-300 psi
BURDON TUBE & WETTED PARTS	HDP-1 - Phosphorus Bronze Burdon Tube & Brass moving parts HDP-2 - Monel
DIAL TYPE	White background, black graduation scale with dual reading in kg/sq.cm and psi
CASE AND BAZEL	Polished Stainless Steel case with positive seal against weather, moisture & dust. HDP-2 is Glycerine filled.
MOUNTING	Direct
WINDOW	Hardened Glass
ACCURACY	+/- 2% of FSD for middle half of scale
WEIGHT (Approx)	HDP-1 - 0.3 kg HDP-2 - 0.8 kg
APPROVALS	UL Listed & FM Approved
REFERENCE STANDARD	UL 393, NFPA-13 FM CLASS NUMBER 2311
ORDERING INFORMATION	Specify connection & Model

DESCRIPTION

Pressure gauges are specifically designed for fire sprinkler services. Model HDP-1 has a corrosion-resistant polished stainless steel 304 case and bezel, along with brass wetted parts. Model HDP-2 has Monel internals and is glycerine-filled. HDP-2 is ideal for seawater applications. The dial displays pressure readings in kg/cm² and psi. The gauge window is made of hardened glass.

The pressure gauge must be mounted using the square provided for spanner grip on the socket, not by turning the case. Turning the case can damage the gauge. Use PTFE tape around the male threads of the gauge for sealing. The pressure gauge must be mounted in a vertical position and isolated with a valve. The pressure gauge must be handled with care.

MODEL:HDP-1

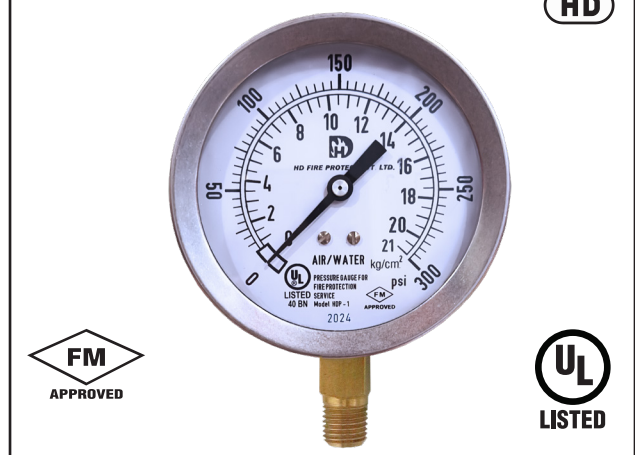

MODEL:HDP-2

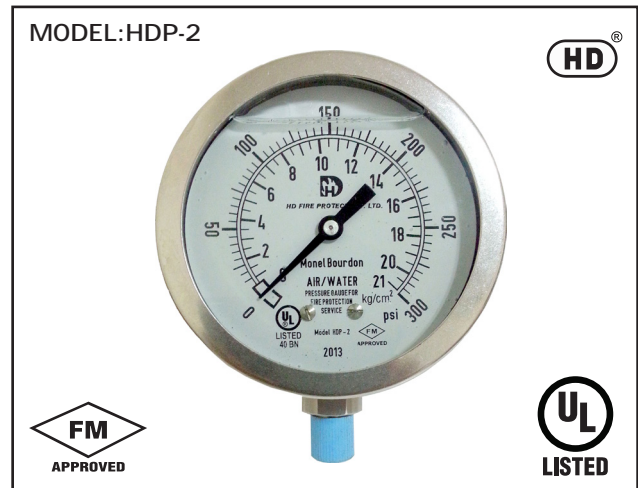

For best results, storage and any further shipments should be made in the original packaging only.

The pressure gauge which is visibly damaged, should not be installed. It is recommended that the pressure gauges must be inspected regularly for possible corrosion or damage.

The gauge must be periodically calibrated as per requirement of NFPA or as per local authority having jurisdiction.

CAUTION

- 1) Do not over tighten the Gauge
- 2) Do not tighten the gauge by holding dial. Always use spanner to tighten.
- 3) In order to prevent any pressure surges, shut-off device/ isolation valve must only be opened slowly.

Note:

Pressure gauges are mass calibrated, hence individual calibration certificate is not provided.

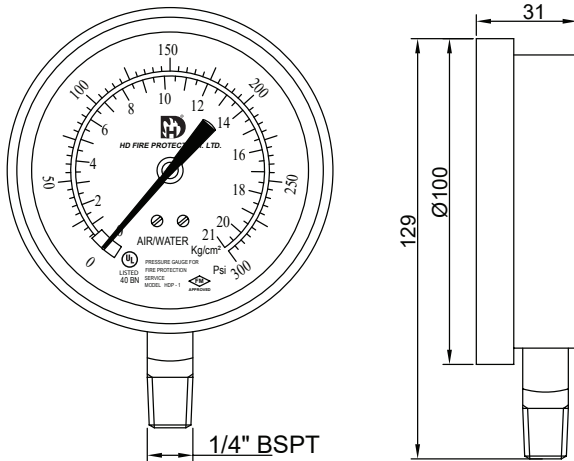
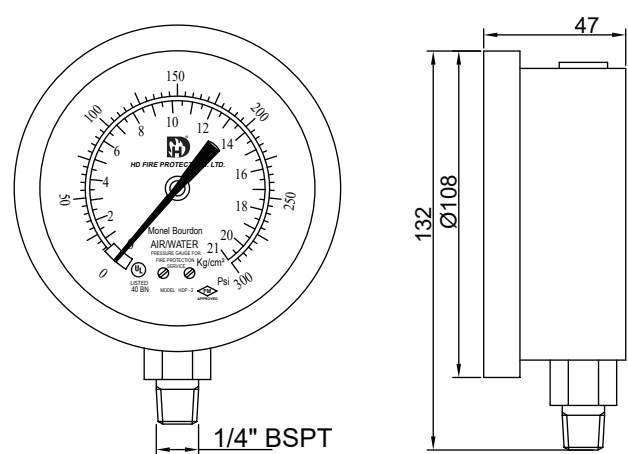
HDP-1

HDP-2

LIMITED WARRANTY

HD FIRE PROTECT PVT. LTD. hereby referred to as HD FIRE warrants to the original purchaser of the fire protection products manufactured by HD FIRE and to any other person to whom such equipment is transferred, that such products will be free from defect in material and workmanship under normal use and care, for two (2) years from the date of shipment by HD FIRE. Products or Components supplied or used by HD FIRE, but manufactured by others, are warranted only to the extent of the manufacturer's warranty. No warranty is given for product or components which have been subject to misuse, improper installation, corrosion, unauthorized repair, alteration or un-maintained. HD FIRE shall not be responsible for system design errors or improper installation or inaccurate or incomplete information supplied by buyer or buyer's representatives. HD FIRE will repair or replace defective material free of charge, which is returned to our factory, transportation charge prepaid, provided after our inspection the material is found to have been defective at the time of initial shipment from our works. HD FIRE shall not be liable for any incidental or consequential loss, damage or expense arising directly or indirectly from the use of the product including damages for injury to person, damages to property and penalties resulting from any products and components manufactured by HD FIRE. HD FIRE shall not be liable for any damages or labour charges or expense in making repair or adjustment to the product. HD FIRE shall not be liable for any damages or charges sustained in the adaptation or use of its engineering data & services. In no event shall HD Fire's product liability exceed an amount equal to the sale price. The foregoing warranty is exclusive and in lieu of all other warranties and representation whether expressed, implied, oral or written, including but not limited to, any implied warranties or merchantability or fitness for a particular purpose. All such other warranties and representations are hereby cancelled.

NOTICE :

The equipment presented in this bulletin is to be installed in accordance with the latest publication standards of NFPA or other similar organisations and also with the provision of government codes or ordinances wherever applicable.

The information provided by us is to the best of our knowledge and belief, and consist of general guidelines only. Site handling and installation control is not in our scope. Hence we give no guarantee for result and take no liability for damages, loss or penalties whatsoever, resulting from our suggestion, information, recommendation or damages due to our product.

Product development is a continuous programme of HD FIRE PROTECT PVT. LTD. and hence the right to modify any specification without prior notice is reserved with the company.